

## FITTING INSTRUCTION

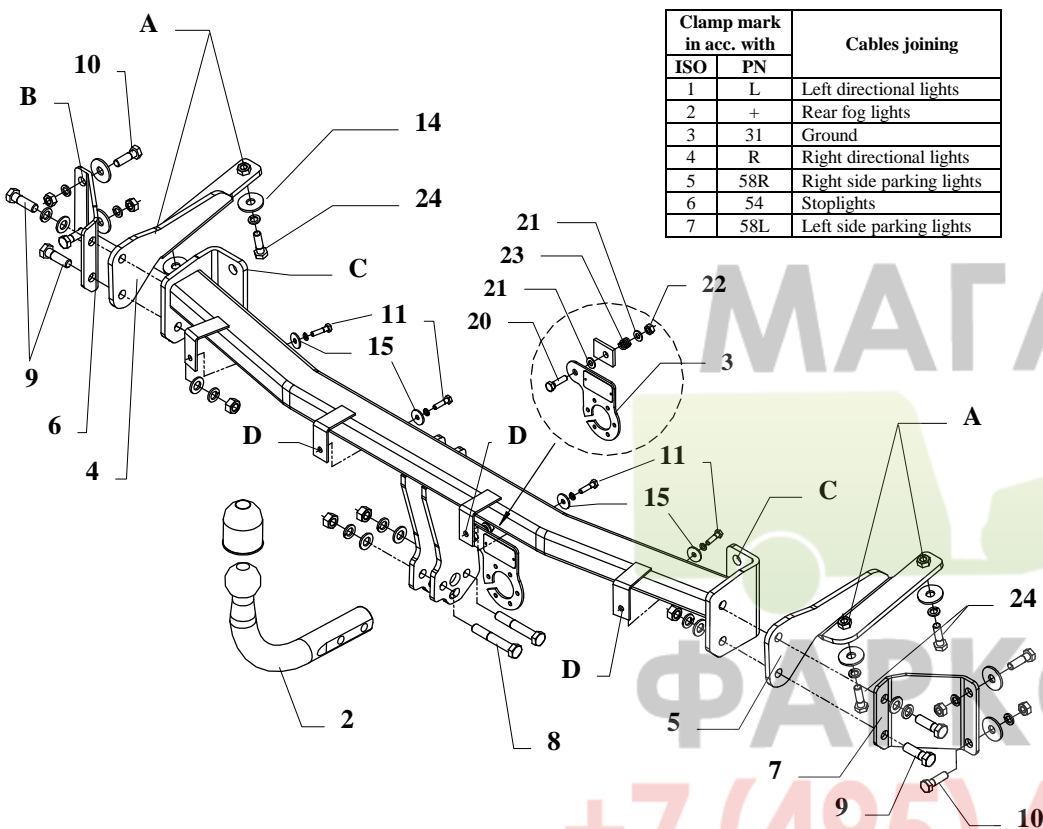

This towbar is designed to assembly in following car: **VOLKSWAGEN CADDY III also MAXI**, produced since 02.2004, catalogue no. **K45** and is prepared to tow trailers max total weight **1500 kg** and max vertical load **75 kg**.

*From manufacturer*

Thank you for buying our product. Their reliability has been confirmed in many tests. Reliability of towbar depends also on correct assembly and right operation. For this reasons we kindly ask to read carefully this instruction and apply to hints.

*The towbar should be install in points described by a car producer.*

## Fitting instructions

1. Disassemble the rear bumper and metal reinforcement (reinforcement will be not used any more).
2. Through holes pos. A fix side brackets (pos. 4 and 5) to chassis using bots M12x30mm (pos. 24), use big washers  $\varnothing 35 \times 12 \times 3$  pos. 14.
3. Between mounted brackets slip main bar of the towbar (pos. 1) in this way, so holes pos. C tally with pins protruding from rear piece. Fix bar to rear piece using original nuts from unscrewed reinforcement of the bumper. Put side handles pos. 6 and 7. Fix it with main bar using bolts M12x40mm (pos.9).
4. Make wanting hole (pos. B) with bit  $\varnothing 11$ mm, next fix side brackets (pos. 6 and 7) by bolts M10x30mm pos. 10.
5. Fix bumper to the towbar through holes D by bolts M6x15mm pos. 11 and washers  $\varnothing 22 \times \varnothing 6 \times 2$  pos. 15.
6. Fix the socket plate (pos. 3) as shown on the drawing.
7. Fix tow-ball (pos. 2) using bolts M12x70mm (pos. 8) from accessories.
8. Tighten all bolts according to the torque shown in the table.
9. Connect electric wires of 7-pole socket according to the instruction of the car. (Recommend to make at authorized service station)
10. Complete paint layer damaged during installation.

Torque settings for nuts and bolts (8,8):

<b>M8</b>	25 Nm	<b>M10</b>	55 Nm
<b>M12</b>	85 Nm	<b>M14</b>	135 Nm











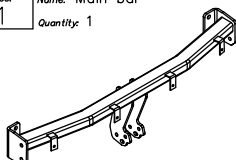







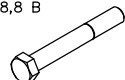





### NOTE

After install the towbar you should get adequate note in registration book (at authorised service station).The car should be equipped with:

- Indicators
- Tow mirrors

After 1000km of exploitation check all bolts and nuts. The ball of towbar must be always kept clear and conserve with a grease.

## Towbar accessories:

Pos. 1 Name: Main bar Quantity: 1 	Pos. 6 Name: Left handle Quantity: 1 	Pos. 12 Name: Nut 8 B Quantity: 4 Dim.: M12 	Pos. 19 Name: Spring washer Quantity: 4 Dim.: Ø 6,5 mm 
	Pos. 7 Name: Right handle Quantity: 1 	Pos. 13 Name: Nut 8 B Quantity: 1 Dim.: M10 	Pos. 20 Name: Bolt 8,8 B Quantity: 1 Dim.: M8x30mm 
Pos. 2 Name: Tow ball Quantity: 1 	Pos. 8 Name: Bolt 8,8 B Quantity: 2 Dim.: M12x70mm 	Pos. 14 Name: Washer Quantity: 8 Dim.: Ø35xØ12x3mm 	Pos. 21 Name: Plain washer Quantity: 2 Dim.: Ø 8,5 mm 
Pos. 3 Name: Socket plate Quantity: 1 	Pos. 9 Name: Bolt 8,8 B Quantity: 4 Dim.: M12x40mm 	Pos. 15 Name: Washer Quantity: 4 Dim.: Ø22xØ6x2mm 	Pos. 22 Name: Nut 8 B Quantity: 1 Dim.: M8 
Pos. 4 Name: Left bracket Quantity: 1 	Pos. 10 Name: Bolt 8,8 B Quantity: 8 Dim.: M10x30mm 	Pos. 16 Name: Plain washer Quantity: 6 Dim.: Ø 13 mm 	Pos. 23 Name: Spring Quantity: 1 
Pos. 5 Name: Right bracket Quantity: 1 	Pos. 11 Name: Bolt 8,8 B Quantity: 4 Dim.: M6x15mm 	Pos. 17 Name: Spring washer Quantity: 10 Dim.: Ø 12,2 mm 	Pos. 24 Name: Bolt 8,8 B Quantity: 4 Dim.: M12x30mm 
	Pos. 18 Name: Spring washer Quantity: 4 Dim.: Ø 10,2 mm 	Pos. 25 Name: Ball cover Quantity: 1 	



## PPUH AUTO-HAK S.J.

Produkcja Zaczepek Kulowych  
Henryk & Zbigniew Nejman  
76-200 SŁUPSK ul. Słoneczna 16K  
tel/fax (059) 8-414-414; 8-414-413  
e-mail: [office@autohak.com.pl](mailto:office@autohak.com.pl)  
[www.autohak.com.pl](http://www.autohak.com.pl)

## Towing hitch (without electrical set)

Class: A50-X Cat. no. **K45**

Designed for:

Manufacturer: **VOLKSWAGEN**

Model: **CADDY III also MAXI**

produced since 02.2004

Technical data:

**D-value: 8,98 kN**

maximum trailer weight: **1500 kg**

maximum vertical cup load: **75 kg**

Approval number according to Directive 94/20/EC: **e20\*94/20\*0211\*00**

## Foreword

This towbar is designed according to rules of safety traffic regulations. The towing hitch is a safety component and can be install only by qualified personnel. Any alteration or conversion of the towing hitch is prohibited and would lead to cancellation of design certification. Remove insulating compound and underseal from vehicle (if present) in the area of the matting surfaces of the towing hitch.

The vehicle manufacturer's specifications regarding trailer load and max. vertical cup load are decisive for driving, and values for the towing hitch cannot be exceeded.

*D-value formula:*

$$\frac{\text{Max trailer weight [kg]} \times \text{Max vehicle weight [kg]}}{\text{Max trailer weight [kg]} + \text{Max vehicle weight [kg]}} \times \frac{9,81}{1000} = D \text{ [kN]}$$